



Installation Guide

Manual Canopy

Table of Contents

Introduction

Objective	3
About the Product	3
How it Works	3
The Importance of Proper Installation	4
Special Considerations	4

Pre-installation

System Components	5
Recommended Tools and Hardware	6

Installation

Step 1	
Mounting the Drive Beam	7
Mounting the Drive Beam – Supplementary Notes	9
Mounting the Drive Beam – Quality Inspection	9
Step 2	
Attaching the Canopy	12
Step 3	
Positioning the Stabilizers	13
Step 4	
Securing the Stabilizers	15

Post Installation Considerations

Winter Storage	16
Wind	16
Improper Use	16
Lubricants	16
Cleaning	17

Introduction

Objective

To provide clear and concise installation steps for your ShadeFX retractable canopy. Installing the canopy in accordance with this guide will ensure a successful deployment of your system.

About the Product

ShadeFX retractable canopies are available in three drive options:

1. Manual
2. Rope, and
3. Motor

Installation steps and hardware vary, depending on drive option. This installation guide only pertains to manual canopies. Please contact ShadeFX should you require an installation guide for rope, or motor canopy.

How it Works

The same single-track advantage applies to each drive option. Fabric panels are extended, or retracted as the lead carrier and wing travel the drive beam. The rendering below demonstrates the extension of a canopy from a retracted position.

As the lead carrier extends along the track, the fabric panels extend one at a time. Once the first fabric panel fully extends, the second carrier is engaged to commence extension of the second panel. The same applies to each carrier that follows, until the lead carrier has travelled the entire length of the drive beam.

1. Retracted canopy

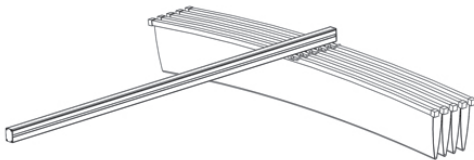

2. Extending lead carrier

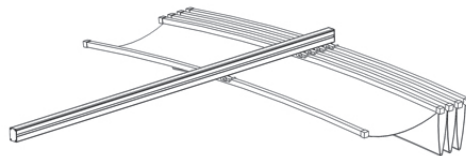

3. Engagement of second carrier

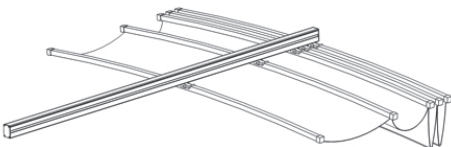

4. Extended canopy

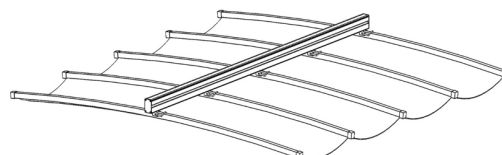

The Importance of Proper Installation

Proper installation will preserve the life the of your ShadeFX retractable canopy. Inadequate installation will result in avoidable, and expedited wear of the system's components.

It is important to note that nearly all structures will vary in material, and size. The installation instructions outlined in the guide are intended to assist with the successful deployment, but are not always absolute.

It is recommended that a complete review of the installation guide be conducted prior to installation. If there are questions regarding installation that are not addressed in the guide, please contact ShadeFX before continuing.

Proper Handling

Proper care must be taken when handling the product during installation, as contact with hard, sharp, or abrasive surfaces could result in deformation, scratches, or rips in the fabric and components of the system.

Special Considerations

Mounting Structure

ShadeFX retractable canopies can weigh in excess of 100lbs, depending on size, and drive type. The structure that the ShadeFX retractable canopy will be mounted to must be capable of supporting the weight load of the system. Before installation, identify the material of the structure. Depending on material type, certain tools (drills, drill bit, etc.) may be required to ensure the canopy is adequately secured to the structure.

Training & Compliance

Most installation work is conducted above ground, from a ladder, or hoist. As such, fall protection training is strongly recommended. Depending on the jurisdiction, licensing or regulatory requirements may apply. Parties installing the ShadeFX retractable canopy should review and comply with local regulations, and adhere to building codes.

Questions

ShadeFX retractable canopies are a unique product, with limited comparable offerings. Whether you are an experienced contractor, or homeowner installing the system for the first time, questions may arise.

ShadeFX Canopies: (855) 509-5509

Pre-installation

The pre-installation section is intended to educate the installer of the various components of the system, recommended tools, and applicable hardware.

Every ShadeFX retractable canopy will include a drive beam, canopy, and hardware. Stabilizers are optional, and can either be acquired directly from ShadeFX, or made on-site from a material that matches the structure (wood, steel, aluminum, etc.). Please note that stabilizers play a vital role in the installation of the canopy, and are explained in further detail later in the guide.

System Components

Drive Beam and Canopy

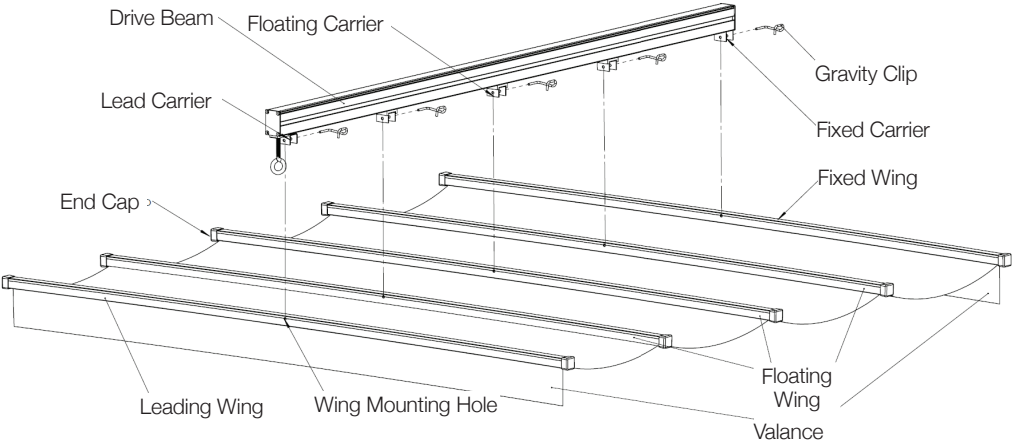

Canopy Stabilizers

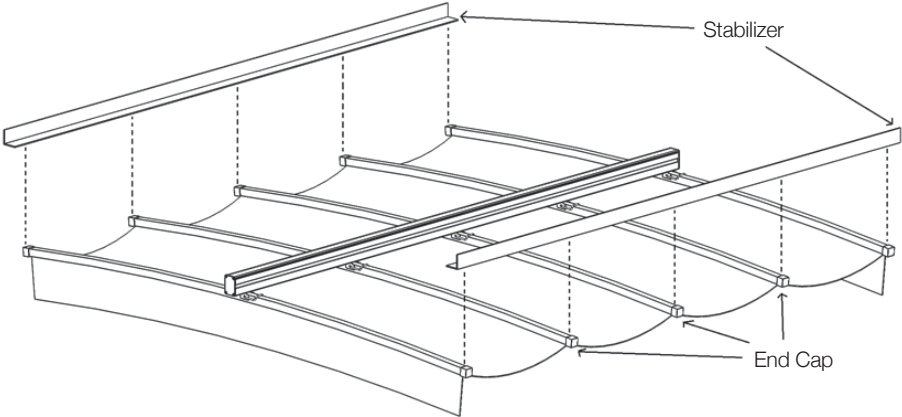

Recommended Tools

The tool listing below is recommended to facilitate an efficient, and effective installation. Certain tools may be substituted.

- Hand drill(s)
- Stepladder(s)
- Tape, or laser measure
- Level
- Socket set
- ¼" Drill bits
- Four quick clamps large enough to secure your drive beam to rafter
- Chalk line, or string line

Hardware

Each canopy drive option is made up of differing hardware kits. The items listed below will be included for a manual canopy. Quantity of hardware will vary with canopy size.

Mounting Screws (Wood Structure)



Mounting Screws (Steel Structure)

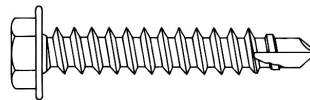

Handle



G-Clip



Installation

The following installation instructions are intended to assist with the installation of a manual canopy and should not be used as a guide to install rope, or motor canopies. Please contact ShadeFX should you require installation instructions for a rope, or motor canopy.

The installation contains four steps. Certain steps will vary depending on canopy options selected, the material of the structure, etc. Each step is laid out for the most common procedure, with supplementary notes for various customizations, and options.

STEP 1: Mounting the Drive Beam

A) Finding the drive beam location on the structure

To determine the location of the drive beam, measure the width of the structure, at the rear. Divide the width in half, to obtain the center point. Add $7/8"$ to both sides of the center, and mark the structure at those points. Repeat the same procedures at the front of the structure. Once the $7/8"$ markings are established at the rear and front of the structure, use a chalk line to create straight lines. The chalk lines will serve as the guide for centering the drive beam. The drive beam will fit inside the guide lines created. Refer to **Figure 1A**

Figure 1A

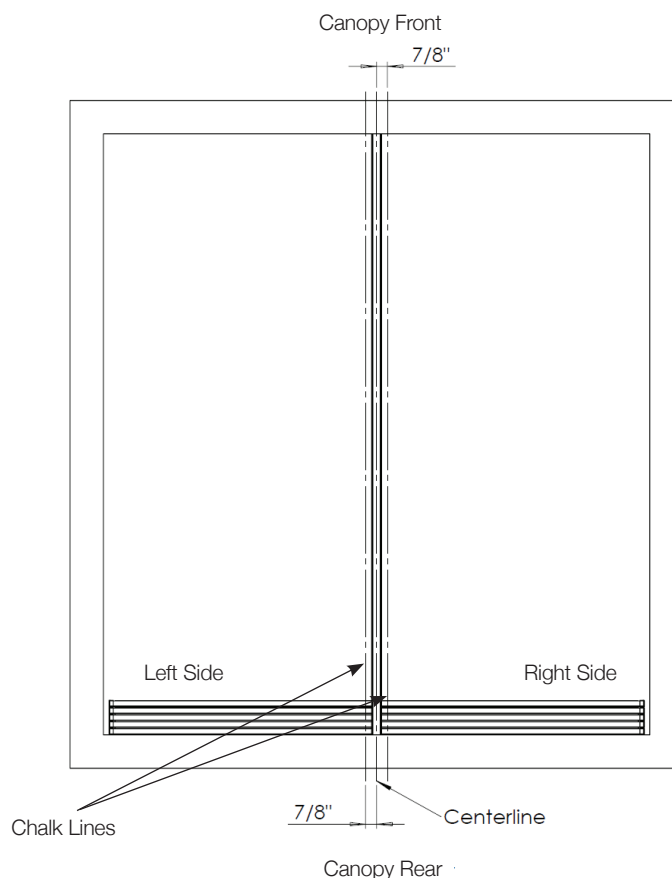

B) Perpendicular vs. parallel rafters

The drive beam can be mounted either perpendicular, or parallel to the structure rafters. If mounting to perpendicular rafters, the span between rafters should not exceed 24". Refer to **Figure 1B**. It is imperative that the rafters are located at an equal height, otherwise the drive beam will deform when mounted. If the rafters are of differing heights, shims should be used to create a flush/flat surface for mounting.

Figure 1B

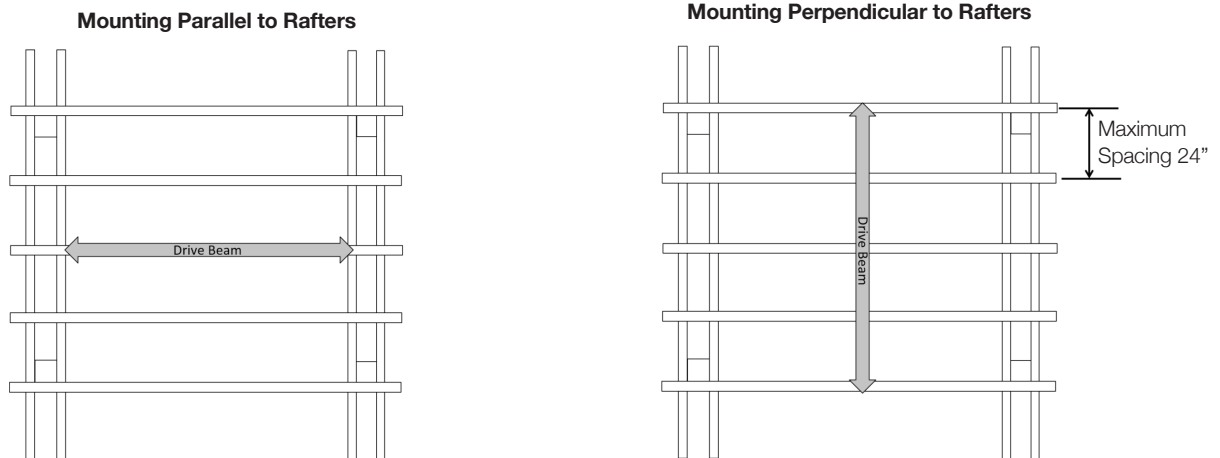

C) Marking mounting screw locations on the drive beam for wood structure

On the underside of the drive beam, mark a center point at both the rear, and front end. Use a chalk line to find the center of the drive beam. Mark and pre-drill two staggered 3/16" holes, every 24" inches, if mounting to a parallel rafter. If mounting to perpendicular rafters, mark and pre-drill two staggered 3/16" holes at every rafter location relative to the drive beam. Refer to **Figure 1C**

Figure 1C

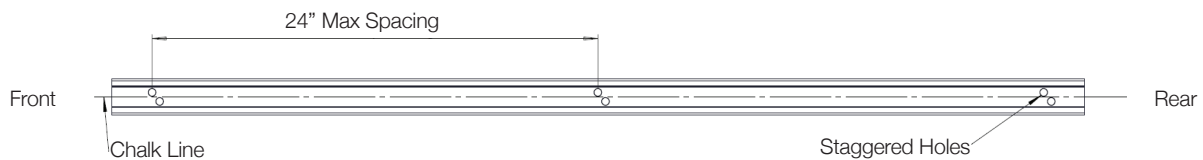

D) Securing the drive beam to the structure

Using clamps, temporarily secure the drive beam to the structure, using the guide lines created in **Step 1A**. Using the mounting screws, fasten the drive beam to the rafters at each pre-drilled location from **Step 1C**. Refer to **Figure 1D**

Figure 1D

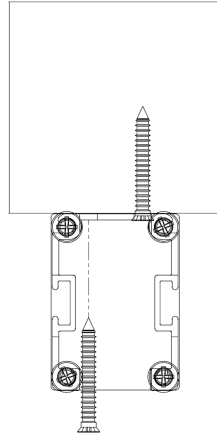

Step 1. Mounting the drive beam – Supplementary notes

E) Finding the drive beam location on the structure for an offset canopy

Offset orientation is always viewed and described from the rear of the structure (retracted position). If the offset is 2" to the right, the drive beam will be installed 2" to the right, of the center point of the structure. Factoring the offset, follow the same procedures as outlined in **Step 1A**. Refer to **Figure 1E** to see illustration of offset.

Figure 1E

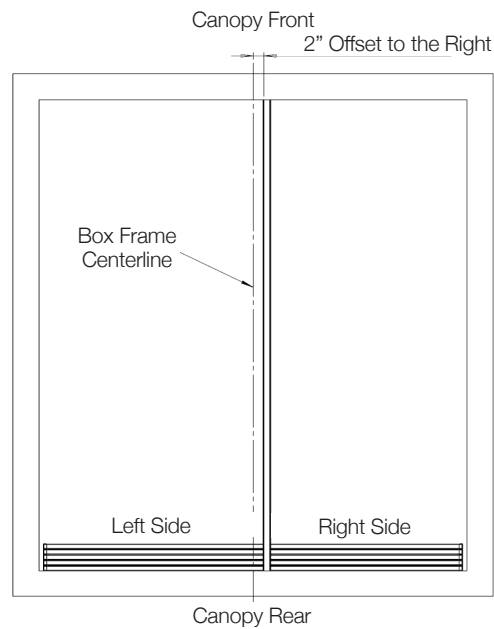

F) Marking mounting screw locations on the drive beam for steel structure

If mounting to a steel structure, the structure will require pre-drilled holes before installing the mounting screws.

On the underside of the drive beam, mark a center point at both the rear, and front end. Use a chalk line to find the center of the drive beam. Mark and pre-drill one centered $3/16$ " holes, every 24" inches, if mounting to a parallel rafter. If mounting to perpendicular rafters, mark and pre-drill the centered $3/16$ " hole at every rafter location, relative to the drive beam. Refer to **Figure 1F**

Figure 1F

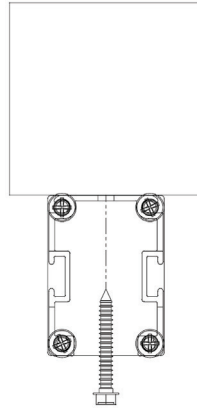

Using clamps, temporarily secure the drive beam to the structure, using the guidelines created in **Step 1A**. Once the drive beam is safely secured temporarily, use the pre-drilled locations on the drive beam to mark the drilling locations on the structure. Unclamp and remove the drive beam to pre-drill the structure locations. Once all locations on the structure are pre-drilled, temporarily secure the drive beam to the structure, using the guide lines created in **Step 1A**. Using the mounting screws, fasten the drive beam to the rafters at each pre-drilled locations.

Quality Inspection

You have now successfully completed the mounting of the drive beam to the structure. Before proceeding to **Step 2**, answer the following questionnaire to ensure the drive beam is appropriately mounted.

- Is the drive beam level across its entire span? Refer to **Figure Q1**

Figure Q1

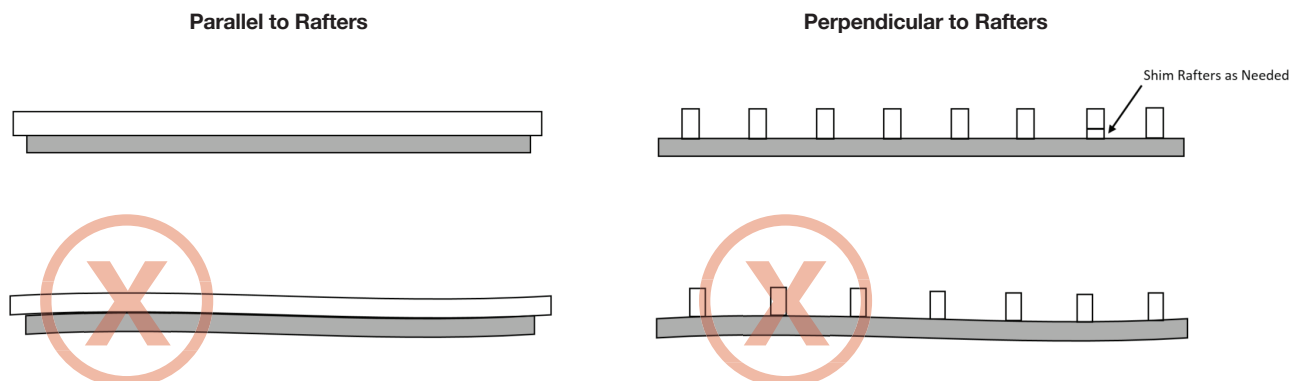

- Is the drive beam straight from rear to front? Refer to **Figure Q2**

Figure Q2

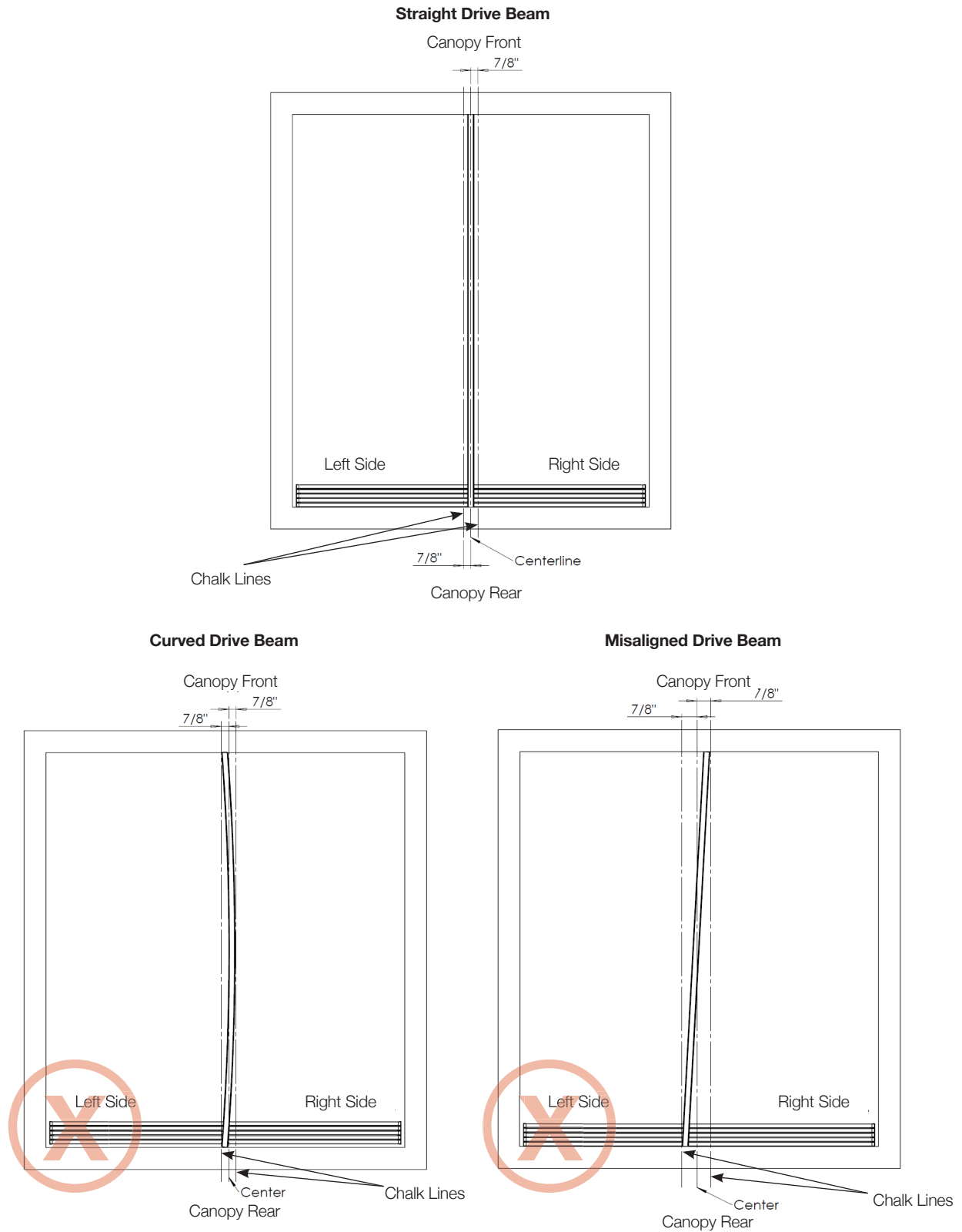

Step 2: Attaching the Canopy

Once the drive beam is adequately mounted, the next step is to attach the canopy. Each wing is to be inserted into a carrier assembly, and secured together by a G-Clip. Start with the rear carrier/wing, and finish with the lead carrier/wing. Refer to **Figure 2**, for a four-step illustration of securing the wing to the carrier assembly.

Figure 2

1. Raise wing into carrier assembly

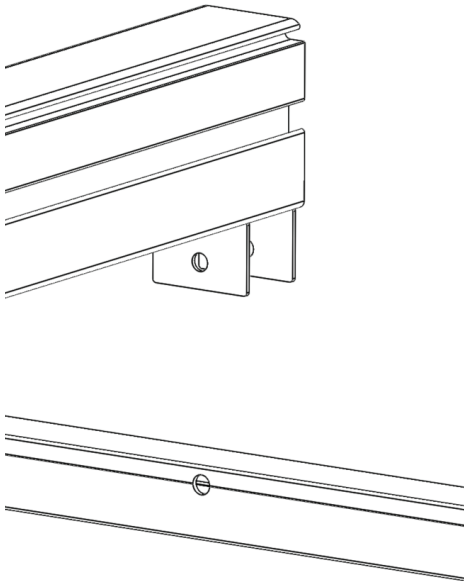

2. Align hole in wing with hole in carrier assembly.
Once holes are aligned, insert the g-clip

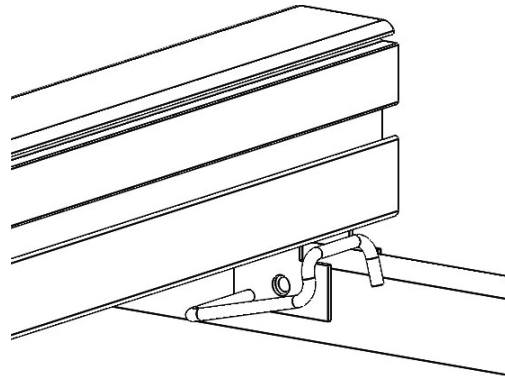

3. Rotate the g-clip downward to lock into position

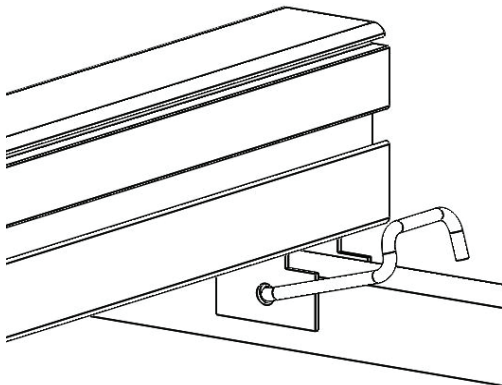

4. Secured wing to carrier assembly

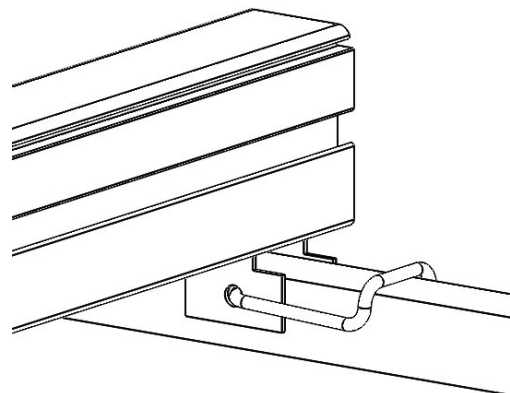

Step 3: Positioning the Stabilizers

It is of the utmost importance that stabilizers are properly located. Improperly installed stabilizers will result in operation complications, and avoidable damage to various components of the canopy system.

The term “deflection”, which will be used in the following procedures, refers to the bending of the wings beyond their natural curved shape, when attached to the carrier assembly. “Deflection” is achieved by increasing the vertical distance between the top of the drive beam and top of the wing tip. The orientation, and the length of the wings determine “Deflection”.

Depending on desired rain management, the orientation of the stabilizers will vary. The following procedures will outline two orientation options. Separate deflection tables are provided for each orientation.

Orientation A: Flat canopy

A flat orientation will deflect rain from the center of the canopy to both sides.

Allow the canopy to rest in its natural position. Refer to **Table 3A**, to determine deflection values. If you have received deflection values from directly from ShadeFX for your system, please use those values.

Table 3A Flat orientation deflections

Wing Length Range (ft)	Deflection Ranges (inches)
8-9	3 ⁵ / ₁₆
9-10	3 ³ / ₈
10-11	3 ⁵ / ₈ - 3 ⁷ / ₈
11-12	3 ⁷ / ₈ - 4 ¹ / ₄
12-13	4 - 4 ⁵ / ₈
13-14	4 ¹ / ₂ - 5
14-15	4 ⁷ / ₈ - 5 ⁵ / ₈
15-16	5 ¹ / ₄ - 6 ¹ / ₄
16-17	5 ³ / ₄ - 7
17-18	6 ¹ / ₂ - 8

Using the values obtained from the table, locate the stabilizer position. The values for deflection refer to the distance between the top of the drive beam (where mounted to structure), to the top of the wing tip. Measure in several places along the length of the structure, and verify that the measurements form a level line, parallel to the drive beam. Refer to **Figure 3A**

Figure 3A

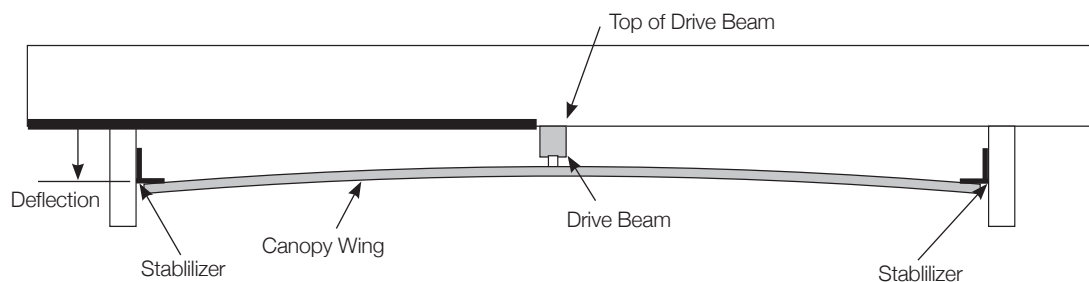

Orientation B: Tilted canopy

A tilted orientation will deflect rain to one side of the canopy.

Allow the canopy to rest in its natural position. Refer to **Table 3B**, to determine deflection values. If you have received deflection values from directly from ShadeFX for your system, please use those values.

Table 3B

Wing Length (ft)	High End Deflection (inches)	Low End Deflection (inches)
8-9	2	4
9-10	1.5	4 1/2
10-11	1	5
11-12	0.5	5 1/2

Using the values obtained from the table, locate the stabilizer position. The values for deflection refer to the distance between the top of the drive beam (where mounted to structure), to the top of the wing tip. Measure in several places along the length of the structure, and verify that the measurements form a level line, parallel to the drive beam. Refer to **Figure 3B**

Figure 3B

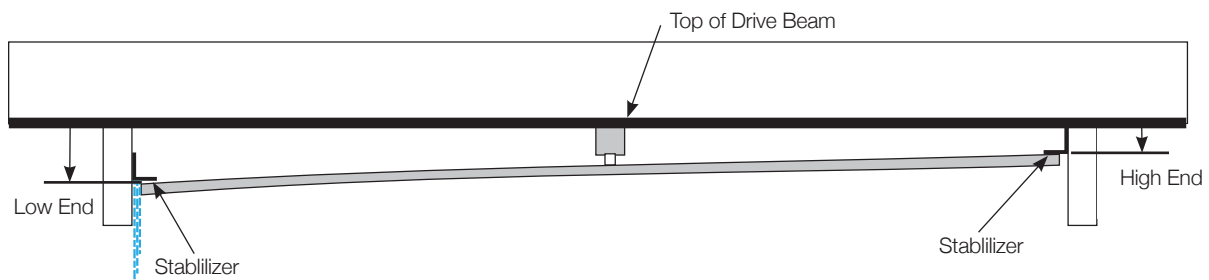

Common Errors When Installing Stabilizers

The following illustrations highlight common errors made when installing stabilizers.

Stabilizers installed underneath the wing

Downward pressure is not achieved if the stabilizers are installed underneath the wings. This deployment will result in chattering, and visible markings/damage to the wings. Refer to illustration below.

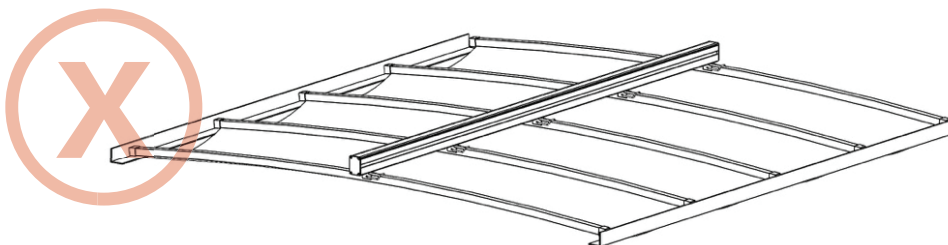

Over-stressed wings

If stabilizers are installed with too much downward pressure, unnecessary resistance will be present when extending and retracting the canopy. Not only will this impact the operation of the system, it will result in deformation of the wings, and can cause severe damage to carrier assembly and fabric. Refer to illustration below.

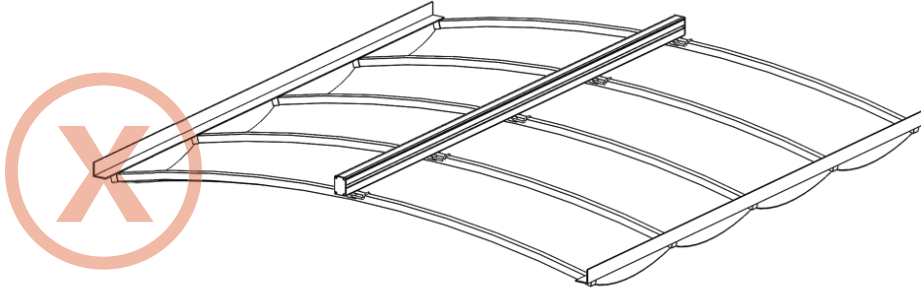

Multiple pieces to create one stabilizer

Stabilizers must be one continuous surface without a break, splice, or joint. Transition areas between pieces can catch the wings, producing excessive tension of the system, compromising its performance, and longevity of its components.

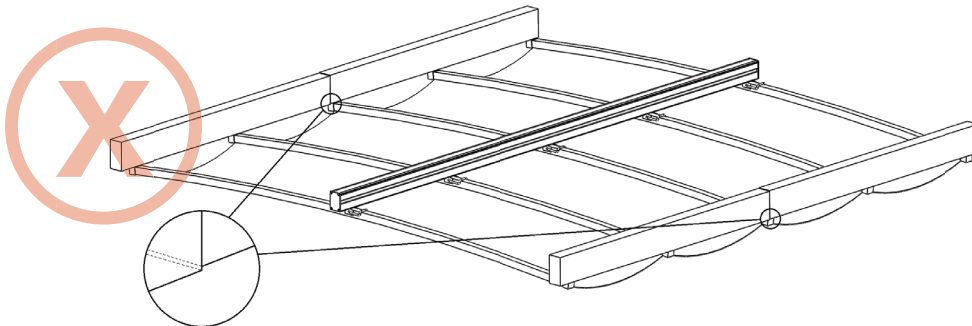

Step 4: Securing the Stabilizers

Once **Step 3** is complete, and the stabilizers appear to be positioned in the appropriate location, tack them at both ends, and the centre. Extend and retract the canopy a couple of times to ensure enough downward pressure is present to keep the system in place, without creating unnecessary tension. Make any necessary adjustments to address downward pressure, and tension, and proceed to permanently secure the stabilizers every 24”.

Post Installation

The following section is intended to inform the canopy user of preventative actions that should be taken to maintain the longevity of the canopy.

Winter Storage

ShadeFX canopies are not engineered to bear snow loads. In colder climates it is recommended the canopies are taken down and stored for the winter. Dismount the canopy by removing the G-clips, and store in a safe place away from the elements. The drive beam and stabilizers will not need to be removed for winter storage. Under no circumstances should the drive beam be operated in freezing temperatures.

Before reattaching the canopy after winter storage, please inspect the canopy, drive beam, and stabilizers to ensure that they are free of debris, and in working order. Inspect the canopy again after reattaching.

Wind

ShadeFX canopies are built to withstand high winds, but should be retracted in winds exceeding 35mph (56kmh). When retracting the canopy in windy situations, operation of the canopy may be more difficult. It is important that the fabric not be blown up into the drive beam by a gust of wind, during retraction. Ensure that the fabric on the retracting canopy folds underneath the drive beam in its usual manner.

Improper Uses of the Product

Do not hang objects such as lights, fans, heater, etc. from any part of the ShadeFX canopy, or drive beam.

When operating a manual drive canopy, do not pull sideways (perpendicular to the drive beam), or downward with the handle.

Do not attempt to alter, or fix any part of the canopy, or drive beam without receiving instruction directly from ShadeFX.

Lubricants

Do not apply any kind of lubricants inside the drive beam or on the carriers. The system is designed and manufactured to be lubricant free.

Canopy Cleaning

Over the years stains may appear from flora, or fauna. Removal of light, and isolated stains can be achieved without dismantling the canopy. If you are cleaning the entire canopy, it is recommended that you take the canopy down.

The following steps are provided to guide the user as to the best method of cleaning the canopy, while mounted to the system.

1. Brush off the loose dirt, with soft bristle brush. **DO NOT USE A STUFF BRISTLED BRUSH.** A stiff bristled brush may scuff the fabric.
2. Hose down the canopy. **DO NOT USE A PRESSURE WASHER.** A pressure washer may pierce/puncture the fabric.
3. Prepare a cleaning solution of water and mild soap such as Woolite or Dawn dishwashing liquid.
4. Use soft bristle brush to clean.
5. Allow cleaning solution to soak into the fabric.
6. Rinse thoroughly until all soap residue is removed.
7. Air dry.
8. If desired, apply fabric sealant, such as Fabric Guard, to protect from water and stains.

The following steps are provided to guide the user as to the best method of cleaning the canopy, when dismantling from the system.

1. Detach the canopy from the drive beam, and lay on a mat larger than the canopy, such as a tarp.
2. Brush off the loose dirt, with a soft bristled brush. **DO NOT USE A STIFF BRISTLED BRUSH.** A stiff bristled brush may scuff the fabric.
3. Pre-soak one panel of the canopy (the fabric section between two wings) with water, and a mild soap such as Woolite or Dawn dishwashing liquid. **DO NOT USE FABRIC DETRERAGENT.** Fabric detergent will remove the hydrophobic sealant on the fabric.
4. Lightly scrub the fabric with a light-bristled brush. **DO NOT USE A STIFF BRISTLED BRUSH.** A stiff bristled brush may scuff the fabric.
5. Wash the soap off with a hose. **DO NOT USE A PRESSUE WASHER.** A pressure washer may pierce/puncture the fabric.
6. Repeat step 2-5 for the remaining panels of the canopy.
7. Leave the canopy to dry.
8. If desired, apply fabric sealant, such as Fabric Guard, to protect from water and stains.
9. Reattach the canopy to the drive beam.

If stubborn stains persist, you may use a diluted bleach/soap mixture for spot cleaning of mildew. For roof run-off or other similar stains, a strong degreaser may be required. Our fabric manufacturer provides a stain chart for specific recommendations. **Refer to the URL below.**

http://www.sunbrella.com/en_us/how/cleaning/stain-chart.php



www.shadefx.com

855-509-5509